

OtoSphere™ – GNSS Protection

Industry's only commercial GNSS protection solution

The innovative device is a small, add-on module to any GNSS-based system that protects it from GNSS jamming attacks.

OtoSphere™ ensures continuity of autonomous navigation and timing signals. OtoSphere™ enables normal operation during jamming conditions. No other solution offers such protection and is as small, light, affordable and easy to install.

OtoSphere™ is unregulated by export control.

Features V2

- Proprietary Interference Filtering Algorithm
- Small form factor: 74 x 47 x 25mm, 150g
- Maximum power consumption: <0.8W (nominal)
- IP67 waterproof rating
- Automotive temperature grade compliant
- Protected frequency: GPS L1 (C/A Code)
- Passthrough frequencies: GPS L5 & Glonass G1 (BeiDou Optional)
- Latency: 100ns ± 15ns (fixed)
- Insertion loss: ±2dB
- Not designed for aerial applications
- Not designed for highly dynamic platforms (< 150km/h)



How does it work?

The Vulnerability of GNSS is well known. Orbiting at 20,000km, the GNSS satellites emit a signal which is incredibly weak when received by GNSS receivers (~-125dBm). To jam or spoof this signal all that is needed is to overpower it. This can be done with a simple jammer bought online to completely block the signal or with a slightly more sophisticated device which can trick the receiver with erroneous data.

Our unique interference filtering algorithm combines the patterns from two omnidirectional antennas. OtoSphere™ analyzes where the interference is coming from and feeds it into its algorithm to filter out the jamming / spoofing signals.

Installation Couldn't Be Easier. After mounting the 2 antennas on a flat, sky-facing, base with at least 10cm separation (optimally > 25cm), connect the antennas to OtoSphere™ and connect it to the antenna input on your GNSS receiver. Feed it with power and the system is defended.

Jamming / Spoofing Detection is available from a LED on the unit itself or via a data output from the device which can be directly integrated to external systems.

Completely Standalone OtoSphere™ is compatible with any GNSS receiver on the market and off-the-shelf GNSS antennas. OtoSphere™ can be supplied with GPS receiver and/or antennas as per customer demand.

Operational Diagram

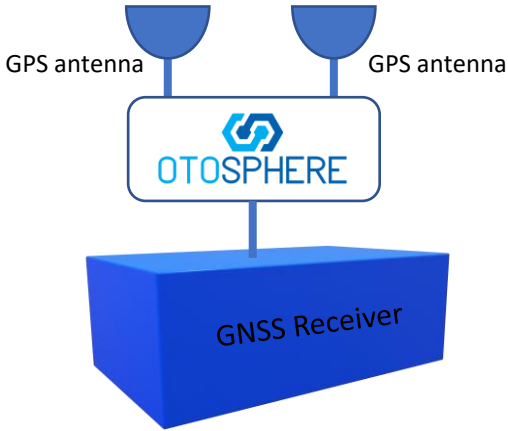

Product Dimensions

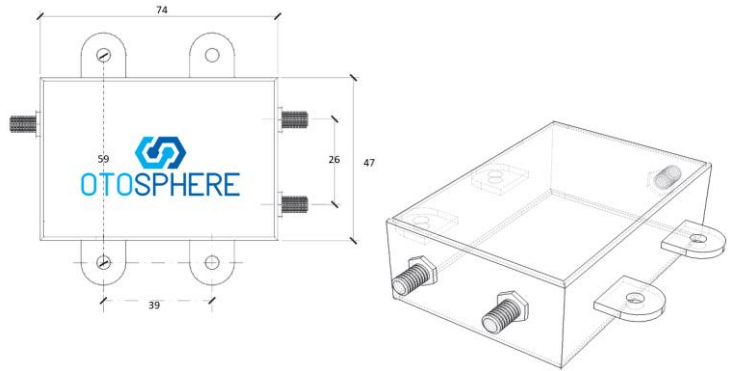

Physical	
Enclosure	74mm x 47 mm x 25mm (excluding mounting lugs)
Weight	150g
Mounting	4 x M3 bolts (not supplied)

Environmental	
Operating Temperature Range	-40°C to 85°C
Waterproof Rating	IP67

RF Interfaces	
Antenna Connectors (P/A)	50Ω SMA 2.75 -3.3 VDC, designed for 26dB ±2dB gain
Receiver Connector (R)	50Ω SMA Requires 3.5 – 32VDC <1W

Performance	
Protected Signal	1575.42 MHz (GPS L1 C/A Code)
Passthrough additional 2 GNSS signals	GPS L5 & Glonass G1
Latency	100ns ±15ns (fixed)
Compression Point	25 dBm
Insertion Loss	±2dB

Safety & Compliance	
FCC compliant	
CE Compliant	
RoHS compliant	

EPS Product Wire Connection Description	
Red Wire	3.5 – 32VDC <1W
Black Wire	GND
Brown Wire	Open drain interference indication

Ordering Information

Product Name	Product Number	Description
OtoSphere v1-EPS	1018	External Power feed (3.5 – 32VDC) and interference indication over 3 wire cable (2.15m length)
OtoSphere v1-PPS	1019	Phantom Power Supply (3.5 – 32VDC) supplied from (R) connector